

Precision Linear Motion Platform

FEATURES

- Compact Low-Profile Design
- 100mm Travel
- Zero backlash, precision ground ball screws
- Optical limit switches with home
- High resolution rotary encoder
- Brushless servo motor drive
- Crossed Roller Bearings
- Power off brake



The LNS-BS Series stages are designed for a variety of applications. This compact low profile ball screw stage is built for high duty cycles and long life and can attain high velocities for factory automation and semiconductor processing equipment. This stage has exceptional levels of accuracy, repeatability, flatness and straightness. The crossed roller bearings and a precision ground ball screw offer extremely smooth operation and velocity control. The LNS-BS Series stages can be stacked to create X, Y and Z motion. The stage can operate in any orientation and has a brake for added safety.



Product Specifications

Encoder Output	A quad B, index
Force X (N)	200
Force Y (N)	250
Force Z (N)	500
Flatness (μm)	5
Height (mm)	45
Length (mm)	289
Limit Switches	Yes
Linear Accuracy (μm)	12
Linear Encoder Resolution (μm)	0.125
Linear Repeatability (μm)	2
Linear Velocity (mm/s)	150
Moment X (N-m)	60
Moment Y (N-m)	275
Moment Z (N-m)	110
Moving Mass X (kg)	1.67
Pitch +/- (arc-sec)	10
Screw Lead (mm)	2
Stage Mass (kg)	3.67
Straightness (μm)	5
Width (mm)	155
Yaw +/- (arc-sec)	10

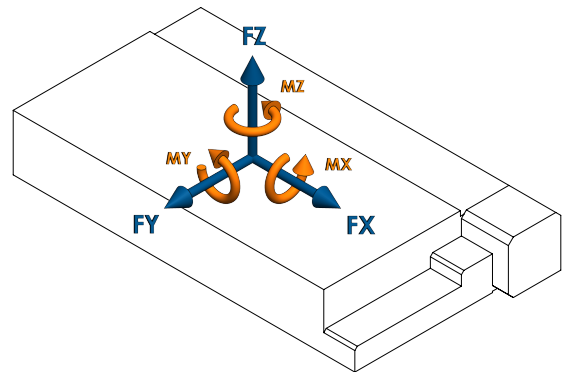

LOAD DIRECTIONS

Part Number Description

LNS	LNS Series
100	100mm Travel
BS	Ball Screw Drive
A	Brushless Servo Motor
H	0.125 μm Rotary
S	Standard Precision
D	Power Off Brake
00	Standar Product (Call for custom)

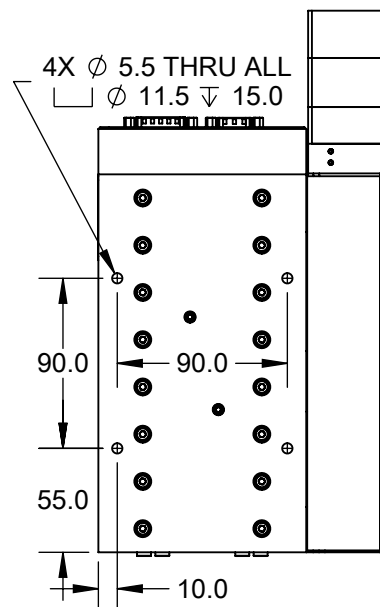
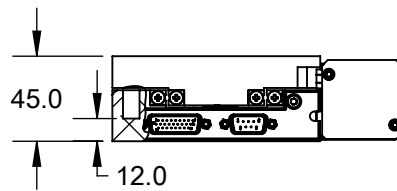
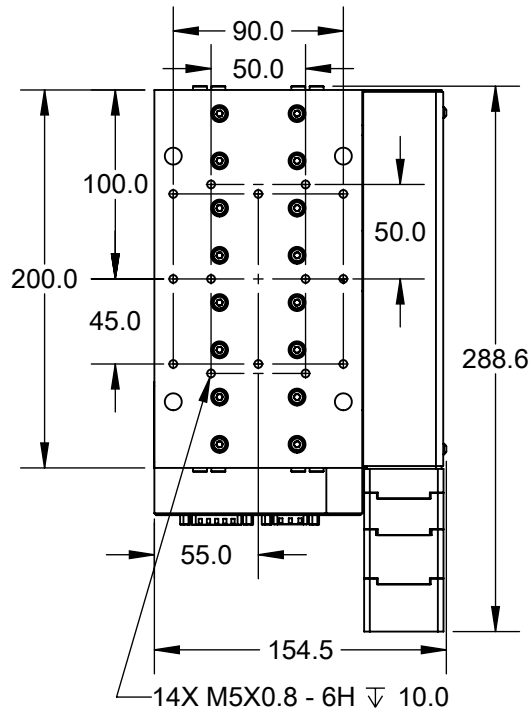

Feedback Connector (DSUB26HD MALE)	
PIN	NAME
1	+5V
2	A+
3	B+
4	RI+
5	LIM+
6	*
7	*
8	*
9	*
10	*
11	A-
12	B-
13	RI-
14	LIM-
15	*
16	*
17	*
18	*
19	GND
20	HALL A
21	HALL B
22	HALL C
23	HOME
24	*
25	*
26	*
* Reserved	

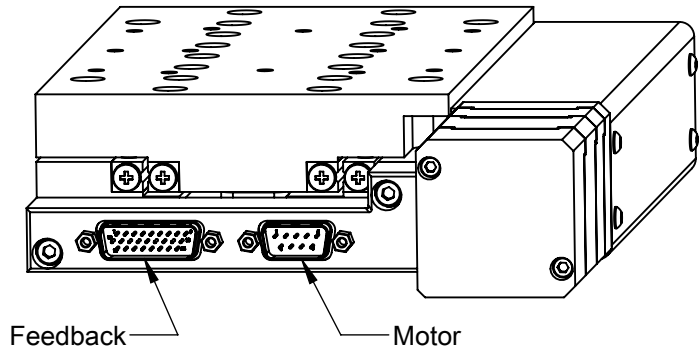

Motor Connector (DSUB9 MALE)	
PIN	NAME
1	*
2	*
3	*
4	BRAKE +
5	BRAKE -
6	PHASE A
7	PHASE B
8	PHASE C
9	*
* Reserved	



LNS-100-BS-A-H-S-D-00

Electrical Specifications

Motor Specifications	
Motor Type	3 Φ Brushless DC
BEMF Constant (V/KRPM)	1.88
Electrical Time Constant (ms)	0.38
Max Bus Voltage (VDC)	24
Max Continuous Current (A)	3.0
Motor Force Constant (N/A)	50.8
Peak Current (A)	10.0
Pin to Pin Inductance (mH)	0.55
Pin to Pin Resistance (ohm)	1.51
Poles per Revolution	6

Brake Specifications	
Brake Type	Power Off Engaged
Winding Voltage (VDC)	24.0
Winding Current (A)	0.17
Winding Resistance (Ohm)	138

Feedback Specifications	
Supply Voltage (V)	5.0 \pm 10%
Supply Current (mA)	250
Encoder Feedback	Yes
Encoder Type	Incremental
Encoder Output	Square Wave Quadrature, RS-422 compatible, A,B,Z, Differential Pairs
Encoder Resolution	8000 cts/mm
Hall Switch Output	Open-Collector, No Pullup Resistor
Hall Switch max current (mA)	-20
Limit Switches	Yes
Limit Switch Output Type	CMOS
Limit Switch Output current (mA)	\pm 20.0
Home Switch	Yes
Home Switch Output Type	CMOS
Home Switch Output current (mA)	\pm 20.0

A home switch is provided near center mechanical travel and a limit switch at each end of travel. The encoder will output one index pulse per revolution of the motor. This pulse is highly repeatable and can be used in coordination with the home switch to find an absolute position after power-up.

The limit switches will be pulled low throughout the travel range of the stage. The output will swing high at the end of travel and remain high until the mechanical limit of the stage is reached.