

## Precision Rotary Table

### FEATURES

- Compact Low-Profile Design
- Continuous 360° rotation
- 30mm through bore
- High resolution encoder
- Precision index mark for homing
- Direct drive brushless servo motor

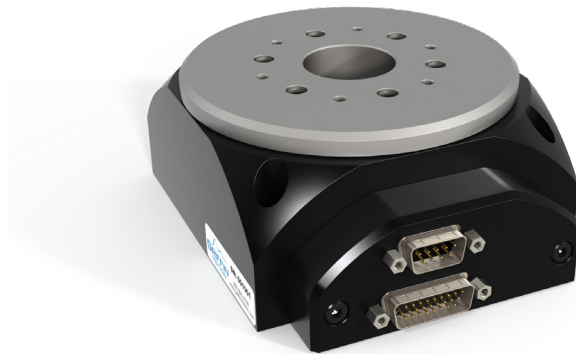

The RTS-DD Series Rotary tables are compact, direct drive, precision positioning tables designed for laboratory, factory automation and semiconductor processing equipment. The brushless direct drive technology eliminates backlash and improves reliability by eliminating sliding friction throughout the stage. The compact stage profile helps to minimize abbe error when used in conjunction with other motion axis. The bore allows convenient routing of vacuum or high voltage lines for a range of wafer chucks. Positioning resolution can be selected to meet the needs of the final application.



RTS-DD-100-M-E-S-P-0-00

## Motion Specifications

## Product Specifications

Angular Accuracy (arc-sec)	20*
Angular Repeatability (arc-sec)	2*
Angular Velocity (deg/s)	4800*
Axial Runout ( $\mu\text{m}$ )	3
Encoder Output	1Vp-p sine and cosine, index
Force X (N)	110
Force Y (N)	110
Force Z (N)	250
Height (mm)	55
Length (mm)	133
Limit Switches	No
Moment X (N-m)	10
Moment Y (N-m)	10
Moment Z (N-m)	Same as Torque
Encoder Resolution (arc-sec)	10,000 sine periods / rev
Radial Runout ( $\mu\text{m}$ )	3
Rotational Inertia ( $\text{kg}\cdot\text{m}^2$ )	0.00136
Stage Mass (kg)	2.34
Torque, Continuous (N-m)	0.65
Torque, Peak (N-m)	1.30
Travel Range (deg)	360 continuous
Width (mm)	110
Wobble (arc-sec)	6
*Subject to control configuration	

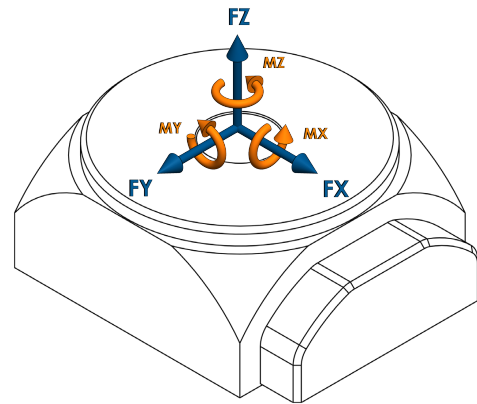

**LOAD DIRECTIONS**

## Part Number Description

RTS	RTS Series
DD	Direct Drive
100	100mm Diameter
M	Glass Disk, 10000 Line Pairs
E	Sinusoidal Output
S	Stainless Steel Hub
P	High Precision
0	No Additional Options
00	Standard Product (Call for custom)

RTS-DD-100-M-E-S-P-0-00

**Mechanical Specifications**

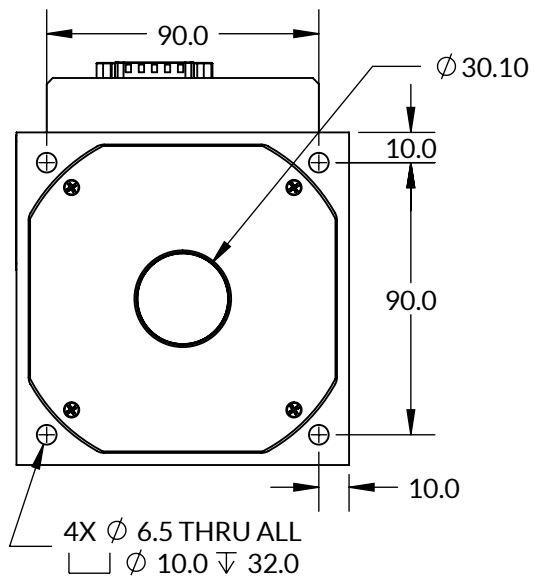
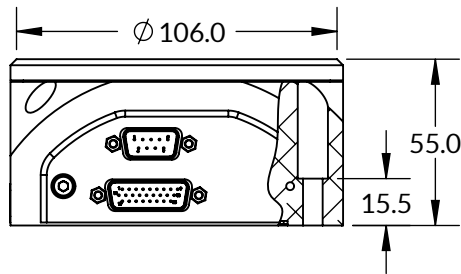
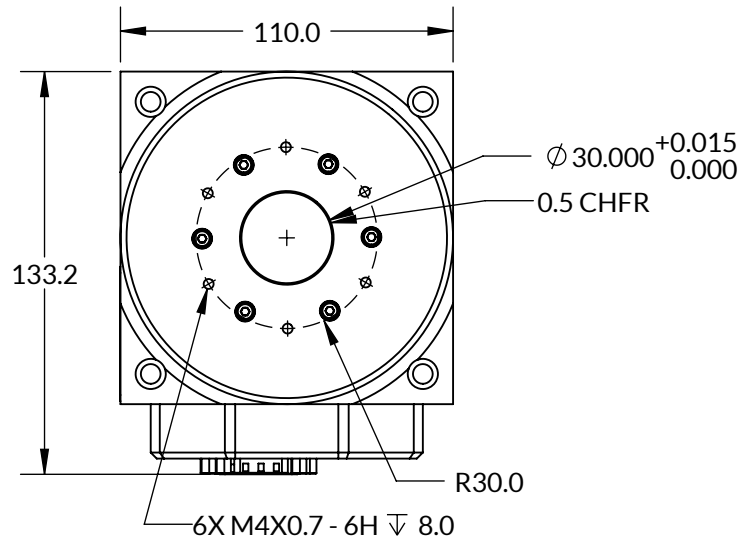

Feedback Connector (DSUB26HD MALE)	
PIN	NAME
1	+5Vdc
2	SIN+
3	COS+
4	INDEX+
5	*
6	*
7	*
8	*
9	*
10	*
11	SIN-
12	COS-
13	INDEX-
14	*
15	*
16	*
17	*
18	*
19	GND
20	HALL A
21	HALL B
22	HALL C
23	*
24	*
25	*
26	*
*Reserved	

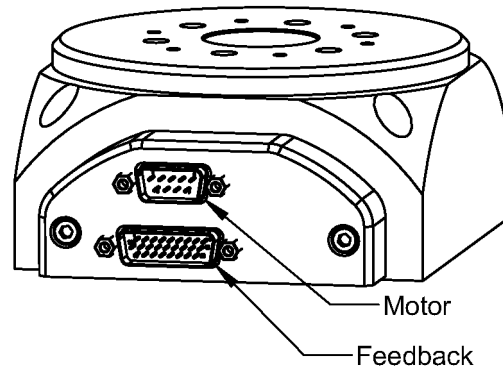

Motor Connector (DSUB9 MALE)	
PIN	NAME
1	PE
2	*
3	*
4	*
5	*
6	PHASE A
7	PHASE B
8	PHASE C
9	*
*Reserved	



RTS-DD-100-M-E-S-P-0-00

## Electrical Specifications

Motor Specifications	
Motor Type	3 phase brushless DC
BEMF Output (Vpk/Krpm)	20.685
Electrical Time Constant (msec)	0.882
Bus Voltage (Vdc)	24 nominal (100 max)
Max Continuous Current (A <sub>pk</sub> )	4.51*
Motor Torque Constant (Nm/A <sub>pk</sub> )	0.171
Peak Current (A <sub>pk</sub> )	9.02
Pin to Pin Inductance (mH)	2.308
Pin to Pin Resistance (ohm)	2.616
Poles Per Revolution	12
*Assumes stage mounted to an aluminum heat sink (330 mm * 330mm * 25mm) in ambient 27°C still air.	

Feedback Specifications	
Supply Voltage (Vdc)	5.0 ± 10%
Supply Current (mA)	350
Encoder Feedback	Yes
Encoder Type	Incremental
Encoder Output Type	1V <sub>pp</sub> Sinusoidal; Sin, Cos, Index; Differential Pairs
Hall Switch Feedback	Yes
Hall Switch Output Type	Open-collector, 1k pullup resistor to supply
Hall Switch max current (mA)	-20
Limit Switch Feedback	No
Error Output Feedback	No

The encoder has one index mark. It will output a pulse once per revolution when this index mark is passed. This pulse is highly repeatable and can be used to find an absolute position (within one revolution of the output shaft) upon power-up.