

Precision XY Gantry with Z Axis

FEATURES

- 300mm X and Y Travel
- 50-150mm Z Travel
- High speed linear motors
- Precision Z ball screw stage with optional brake
- Full cable management for stages and customer application
- Extremely high levels of orthogonality, flatness, and repeatability

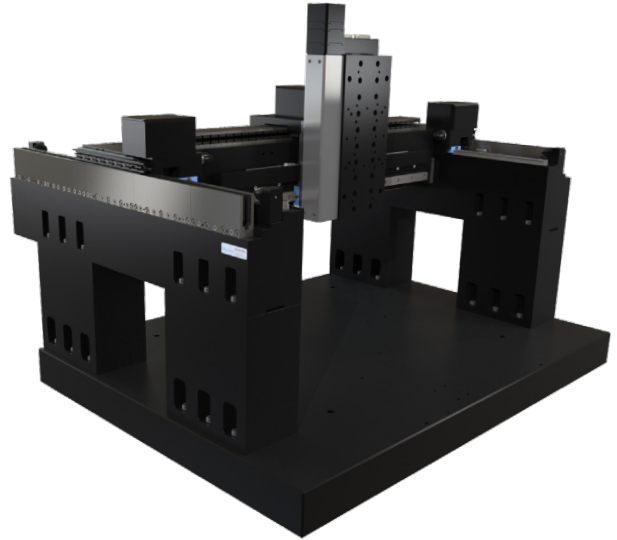

Gantry system assemblies are designed for a variety of applications. They combine multiple axis of motion to create a high precision work envelope. This system is built for high duty cycles and long life and can attain high velocities for factory automation and semiconductor processing equipment. The precision Z ball screw stage can be configured for different required travels ranging from 50mm to 150mm. Integrated cable management for both the stage and customer mounted pieces are available.



Product Specifications

Encoder Output (X and Y)	1Vpp
Encoder Output (Z)	RS422
Height (mm) with 150mm Z stage	603
Length (mm)	677
Limit Switches	Yes
Linear X and Y Accuracy +/- (μm)*	15
Linear X and Y Repeatability +/- (μm)	2
Linear Z Accuracy +/- (μm)*	10
Linear Z Repeatability +/- (μm)	2
Linear X and Y Velocity (mm/s)	4000
Linear Z Velocity (mm/s)	150
Stage Mass (kg)	160
Squareness (arc-sec)*	15
Width (mm)	800

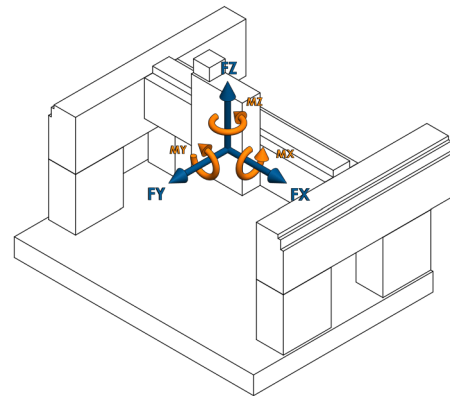

LOAD DIRECTIONS

*Higher accuracy possible with calibration and proper controls

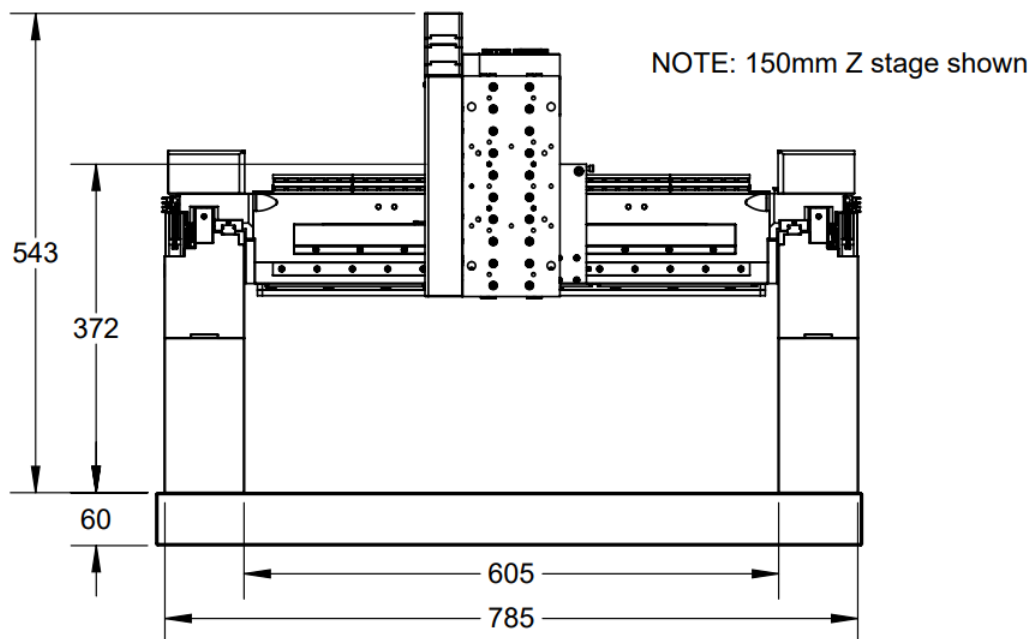
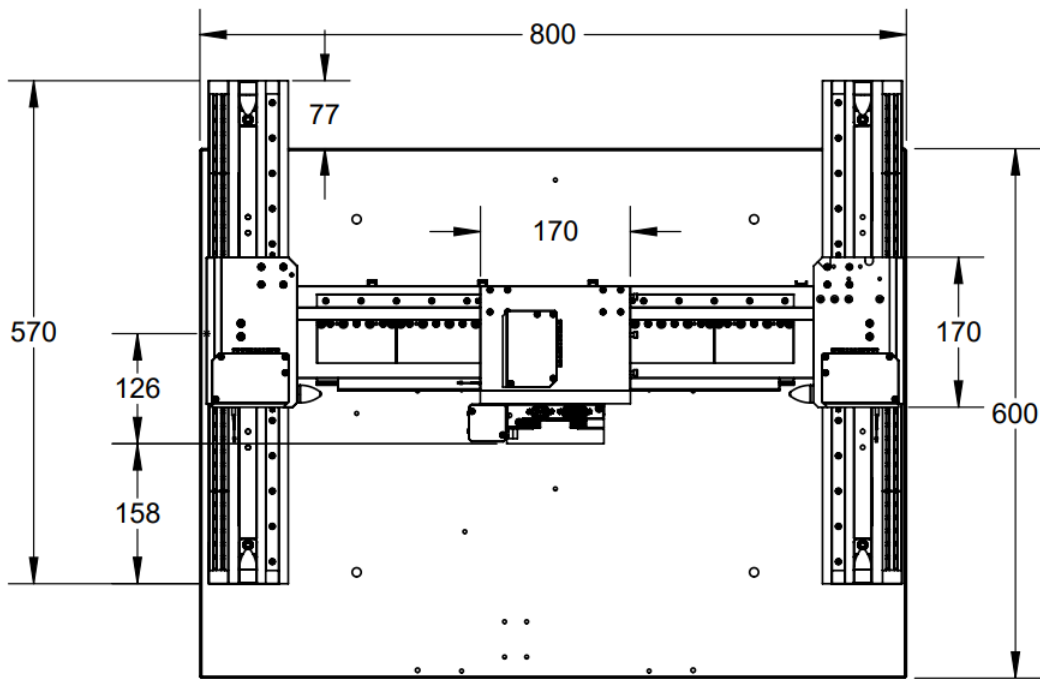

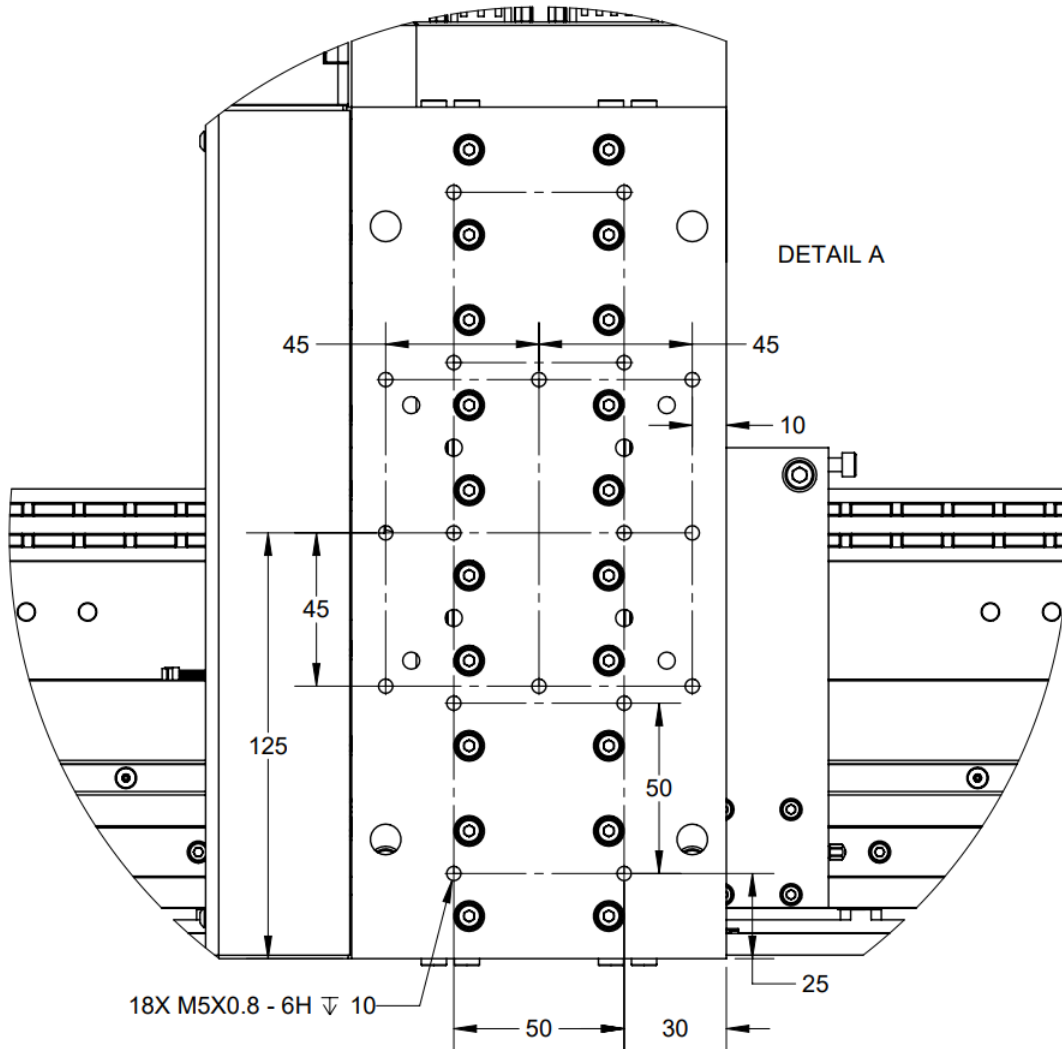
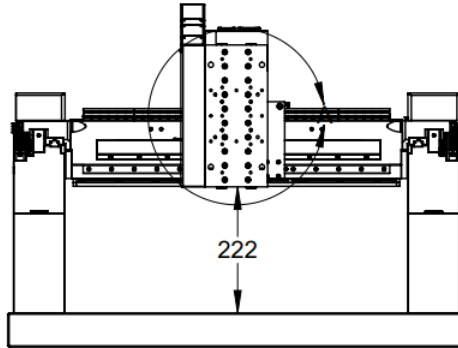

Note: All axes use 26 position DSUB feedback connector. X, Y and YY use 5W5 style DSUB connector for motor signals. Z axis uses 9 position DSUB for motor.

X, Y and YY AXES Feedback Connector (DSUB26HD MALE)	
PIN	NAME
1	+5V
2	SIN+
3	COS+
4	IDX+
5	LIM+
6	*
7	*
8	*
9	*
10	*
11	SIN-
12	COS-
13	IDX-
14	LIM-
15	*
16	*
17	*
18	*
19	GND
20	HALL A
21	HALL B
22	HALL C
23	*
24	*
25	*
26	*
* Reserved	

Z AXIS Feedback Connector (DSUB26HD MALE)	
PIN	NAME
1	+5V
2	A+
3	B+
4	Z+
5	LIM+
6	*
7	*
8	*
9	*
10	*
11	A-
12	B-
13	Z-
14	LIM-
15	*
16	*
17	*
18	*
19	GND
20	HALL A
21	HALL B
22	HALL C
23	*
24	*
25	*
26	*
* Reserved	

X, Y and YY AXES Motor Connector (DSUB5W5 MALE)	
PIN	NAME
A1	PHASE A
A2	PHASE B
A3	PHASE C
A4	*
A5	MOTOR/HOUSING SHIELD
* Reserved	

Z AXIS Motor Connector (DSUB9 MALE)	
PIN	NAME
1	*
2	*
3	*
4	BRAKE
5	BRAKE
6	PHASE A
7	PHASE B
8	PHASE C
9	*
* Reserved	

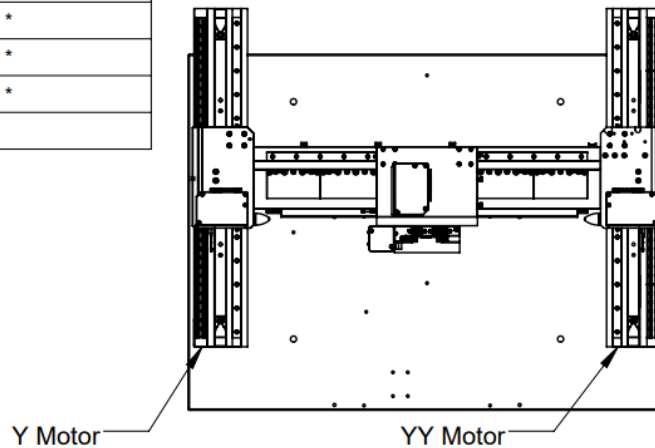



GT3-300-300-XXX

Electrical Specifications

Parameter	Unit	Axis			
		X	Y	YY	Z
Motor Type		Ironless 3Φ Brushless DC	Ironless 3Φ Brushless DC	Ironless 3Φ Brushless DC	3Φ Brushless DC
VBUS, Max	VDC	340	340	340	48
Force, Continuous	N	58	58	58	200
Force, Peak	N	200	200	200	400
Force Constant	N/Ap	26	26	26	
BEMF Constant	V/m/s	30	30	30	
Pole Pitch	mm	30	30	30	
*Speed, Max	mm/s	4000	4000	4000	150
Current, Continous	Amps(peak-of-sine)	2.26	2.26	2.26	
Current, Peak	Amps(peak-of-sine)	7.78	7.78	7.78	
Resistance, pin-pin	Ohm	18.6	18.6	18.6	
Inductance, pin-pin	mH	6	6	6	
Torque, Continuous	Nm				0.080
Torque, Peak	Nm				0.160
BEMF Constant	V/KRPM				2.840
Torque Constant	Nm/Ap				0.023
Poles	N/rev				6
Ball Screw Pitch	mm/rev				2
Linear Encoder Resolution	µm/line pair	20	20	20	40
Nominal Stroke	mm	300	300	300	150
Electrical Stroke (between limit switches)	mm	304-306	304-306	304-306	150.1-151.4
Mechanical Stroke (between Hard Stops)	mm	360	360	360	160
Encoder Index Location		center mechanical stroke ±1.0	center mechanical stroke ±1.0	center mechanical stroke ±1.0	+70mm from center mechanical ±0.5
Encoder Output		1Vpp	1Vpp	1Vpp	RS422
**Moving Mass	kg	7.5	22.5		2.06
**Total System Mass	kg	160			

*Maximum motor and feedback velocity, application requirements such as VBUS or payload mass may further limit speed
 **Without customer cables or payload